

Class 300 • Union Bonnet* • Rising Stem • SS Seats • Thrd. Ends

Gate Valve Figure B-145

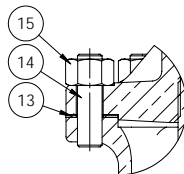

FOR 2 1/2"-3"

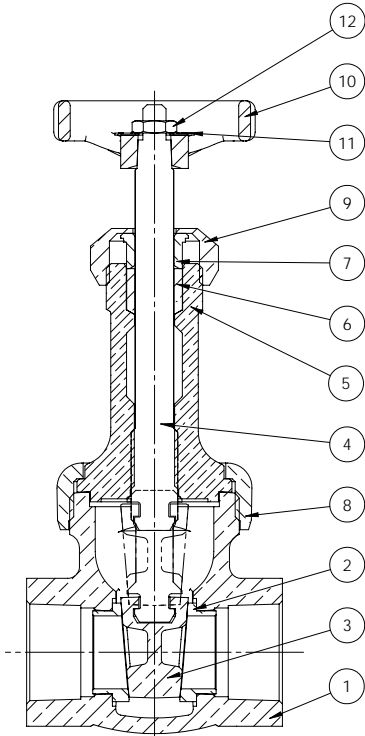
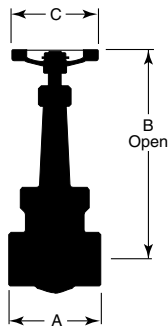

Materials of Construction

No.	Description	Material	ASTM Spec.
1	Body	Bronze	B-61 C92200
2	Body Seat Ring	Stainless Steel	A-276 Type 410
3	Disc	Bronze	B-61 C92200
4	Stem	Bronze	B-371 C69400
5	Bonnet	Bronze	B-61 C92200
6	Packing	Graphite (Asbestos Free)	
7	Gland	Brass	B-16 H02
8	Union Bonnet Ring	Bronze	B-61 C92200
9	Packing Nut	Brass	B-16 H02
10	Handwheel	Cast Iron	
11	ID Plate	Aluminum	
12	Lock Nut	(2 1/2" - 3") Steel Cadmium	
13	Gasket	Synthetic/Glass Fiber with Nitrile Binder	
14	Stud	Steel Cadmium	A-109 C1145
15	Nut	Mild Steel	A-563 GR A

NOTE:

The addition of the letter "K" at the end of the figure number designates valves assembled & tested in the USA. Materials of Construction & Dimensions are the same.

Industry Standards

Complies with MSS SP-80 Type 2

See Page 6 for Pressure-Temperature Ratings

Dimensions and Weights

Inches (millimeters) - Pounds (kilograms)

Valve Size	Dimensions			Wt.
	B	C	A	
1/4	4.67	2.24	2.03	0.88
	(119)	(57)	(52)	(0.40)
3/8	7.43	2.24	2.13	0.90
	(189)	(57)	(54)	(0.41)
1/2	5.37	2.76	2.44	1.43
	(136)	(70)	(62)	(0.65)
3/4	6.56	2.76	2.61	2.07
	(167)	(70)	(66)	(0.94)
1	7.60	2.76	3.06	3.23
	(193)	(70)	(78)	(1.47)
1 1/4	9.09	4.02	3.35	4.86
	(231)	(102)	(85)	(2.21)
1 1/2	10.28	4.02	3.69	6.18
	(261)	(102)	(94)	(2.81)
2	12.17	4.02	3.96	10.36
	(309)	(102)	(101)	(4.71)
*2 1/2	14.36	4.75	4.60	19.21
	(365)	(121)	(117)	(8.73)
*3	16.71	5.51	5.63	32.82
	(425)	(140)	(143)	(14.92)

* 2 1/2" and 3" have Bolted Bonnet